

Model Y Series

Commercial fully automatic coffee machine Model Y650C/Y650C-M/Y680C Y680C-M/Y685C/Y685C-M

Version 1.0



Model Y6 Series

Dear Customer

Thanks a lot for purchasing Y6 series Coffee machine
This is a multifunction coffee machine for Espresso,
Americano, various milk beverages, chocolate beverages
and hot water.

We believe the machine adapts to your customer needs
to the greatest extent.
Hope you enjoy it and also wish you have excellent
experience from it.



Content

1 For your safety	01
1.1 Proper use	01
1.2 Prerequisites for using the coffee machine	01
1.3 Explanation of safety symbols	01
1.4 General safety concerns when using the coffee machine	02
2 Description of machine	05
2.1 Machine overview	05
2.2 Screen interface	07
2.3 Scope of delivery	09
2.4 Technical data	10
3 Installation	12
3.1 Installation tips	12
3.2 Dimensions	12
3.3 Installation location	14
3.4 Electrical connection	14
3.5 Water supply connection	14
4 Start-up for the first time	16
4.1 Material filling	16
4.2 Initially start-up program setting	16
5 Operation	17
5.1 Coffee beans filling	17
5.2 Powder filling	18
5.3 Water tank filling	18
5.4 Milk connection	19
5.5 Empty bean hopper	19
5.6 Empty powder hopper	21
5.7 Switch on machine	22
5.8 Beverage preparation	22
5.9 Steam output	24
5.10 Grinding coarseness setting	25
6 Program setting	25
6.1 Access to the menu	25

Content

6.2 Program setting menu tree	26
6.3 Maintenance	27
6.4 Beverage	29
6.5 System	35
6.6 Operation panel	39
6.7 User	44
6.8 Language	45
6.9 Statistics	45
6.10 Help	46
6.11 IoT function	46
7 Cleaning and maintenance	46
7.1 Cleaning intervals overview	47
7.2 Parts preparation	47
7.3 Daily cleaning	48
7.4 Weekly cleaning	50
7.5 Brew unit cleaning if presents	54
7.6 Milk system cleaning if presents	54
7.7 Descaling if presents	55
8 Messages and explanation	56
8.1 Operational messages	56
8.2 Error message	58
9 Decommissioning	61
9.1 Prepare for decommissioning	61
9.2 Short-term decommissioning (within one month)	61
9.3 Long-term decommissioning (over one month)	61
10 Transport and storage	61
10.1 Transport	61
10.2 Storage	62
10.3 Recommissioning after prolonged periods of storage or non-use	62
11 Disposal	62

1. For your safety

1.1 Proper use

1.1.1 Coffee machine

1. The Y6 series are commercial machines for preparing drinks and are intended for use in food services, offices, hotel, convenience store and other similar environment.
2. The Y6 series are designed to process whole coffee beans, chocolate powder, milk powder and fresh milk.
3. The Y6 series are intended for operation indoors but are not suitable for use outdoors.

1.2 Prerequisites for using the coffee machine

1. The Y6 series are intended for use only by trained personnel.
2. Do not operate the Y6 series or add-on units until you have completely read and understood relative description.
3. Self-service coffee machines must always be monitored to protect the users.
4. Do not use the Y6 series or add-on units if you are not familiar with the various functions.
5. Do not use the Y6 series unless the machine or the add-on units have been cleaned or filled as intended.
6. This appliance is not intended for use by persons (including children) with reduced physical, sensory or mental capabilities, or lack of experience and knowledge, unless they have been given supervision or instruction concerning use of the appliance by a person responsible for their safety. Children should be supervised to ensure that they do not play with the appliance.
7. Do not install the coffee machine in the area of water jet.
8. Clean the coffee machine at least once a day and more frequently if necessary, and only use cleaning tablet, descaling powder supplied by Kalerm. See chapter 7 or Cleaning & Descaling manual for the details.
9. See the following concerns carefully and operate according to the display during maintenance. See chapter 7 or Cleaning & Descaling manual for the details.

1.3 Explanation of safety symbols

Observation of these safety instructions is imperative to ensure personal safety and the intactness of machine. Symbols and signal words indicate the level of hazards as follows:



WARNING

WARNING indicates a potential danger, if not avoided, will probably result in death or serious injury.



CAUTION

CAUTION indicates a hazardous situation which, if not avoided, could result in minor or moderate injury.



NOTICE

NOTICE directs your attention to the risk of damage to machinery.

1.4 General safety concerns when using the coffee machine

Improper use of coffee machine can lead to potential danger during operation. To avoid personal injury and health hazard, please note the following tips when using the coffee machine.



WARNING

Health hazard due to electrical shock

If the supply cord is damaged, it must be replaced by a special cord or assembly available from the manufacturer or its service agent.

1. Damaged power cords, lines or plug connections can lead to electrocution.
2. Do not connect any damaged power cords, lines or plug connections to the power supply.
3. Ensure that the machine and the power cord are not near any hot surfaces such as gas or electric stoves or ovens.
4. Ensure that the power cord is not pinched and does not chafe on sharp edges.
5. Immerse power plug in water or other liquids are not allowed, as well as pouring water or other liquids on the power plug. Power plug must be dry.
6. Repairs or servicing improperly performed on electrical systems can lead to electrocution.
7. Have servicing work carried out by authorized persons with corresponding qualifications only.
8. This appliance incorporates an earth connection for functional purposes.

**WARNING****Danger of suffocation**

1. Plastic packaging materials could cause children to suffocate.
2. Ensure that children and persons with reduced physical, sensory, or mental capabilities have no access to plastic packaging materials.

**CAUTION****Risk of scalding**

1. Hot liquids and steam escape during cleaning and can lead to scalding.
Keep hands away from the spouts and nozzles during this process.
2. Do not put anything on the drip grid.
3. Use only suitable drinking vessels.
4. Always be careful with hot drinks.
5. IN CASE OF SCALDING: Immediately cool the affected area and consult a doctor depending on the severity of the injury.

**CAUTION****Risk of injury**

1. If objects drop into the grinder, splinters may be ejected, leading to injury.
2. Never put any objects into the grinder.

**CAUTION****Cutting injuries/crushing**

1. Active components in the interior of coffee machine will hurt fingers or hands.
2. Remember to switch off coffee machine and unplug the power supply before removing grinder or reaching into brew module.



CAUTION

Irritation from cleaning agent

1. Cleaning tablets, milk system cleaning agent, and descaling agent can lead to irritations.
2. Observe the hazard warnings on the label of the respective cleaner.
3. Avoid contact with your eyes and skin.
4. Wash your hands after contact with cleaning agent. Consult a doctor if necessary.
5. Cleaning agent must not find their way into drinks



CAUTION

Health hazard due to germ formation

1. Inadequate cleaning can result in food residues accumulating in the machine and at the nozzle, thereby contaminating products.
2. Do not use the machine unless it has been cleaned according to the instructions.
3. Clean the machine daily in accordance with the instructions.
4. Inform operating personnel of the necessary cleaning measures.
5. If the machine is not used for extended periods, residue may accumulate. Clean the machine before using.
6. Using a water filter for too long can lead to the build-up of algae. Replace the water filter when prompted to do so by the machine.
7. Coffee beans, powder and fresh milk must in the expiration date.



CAUTION

Risk of mechanical injury

1. The appliance has to be placed in a horizontal position.
2. If the machine has not been drained and emptied completely, it must not be stored at sub-zero temperatures. Put the machine in the temperature about of 20° for 2-4 hours if freezing occurs
3. The appliance should be cleaned in the recommended manner and should not be submerged in water or cleaned with a spray head.

2. Description of machine

2.1 Machine overview

The Y6 series coffee machines are available with numerous options. A sample configuration is illustrated here. Please note that your coffee machine may look different from the configuration shown here.

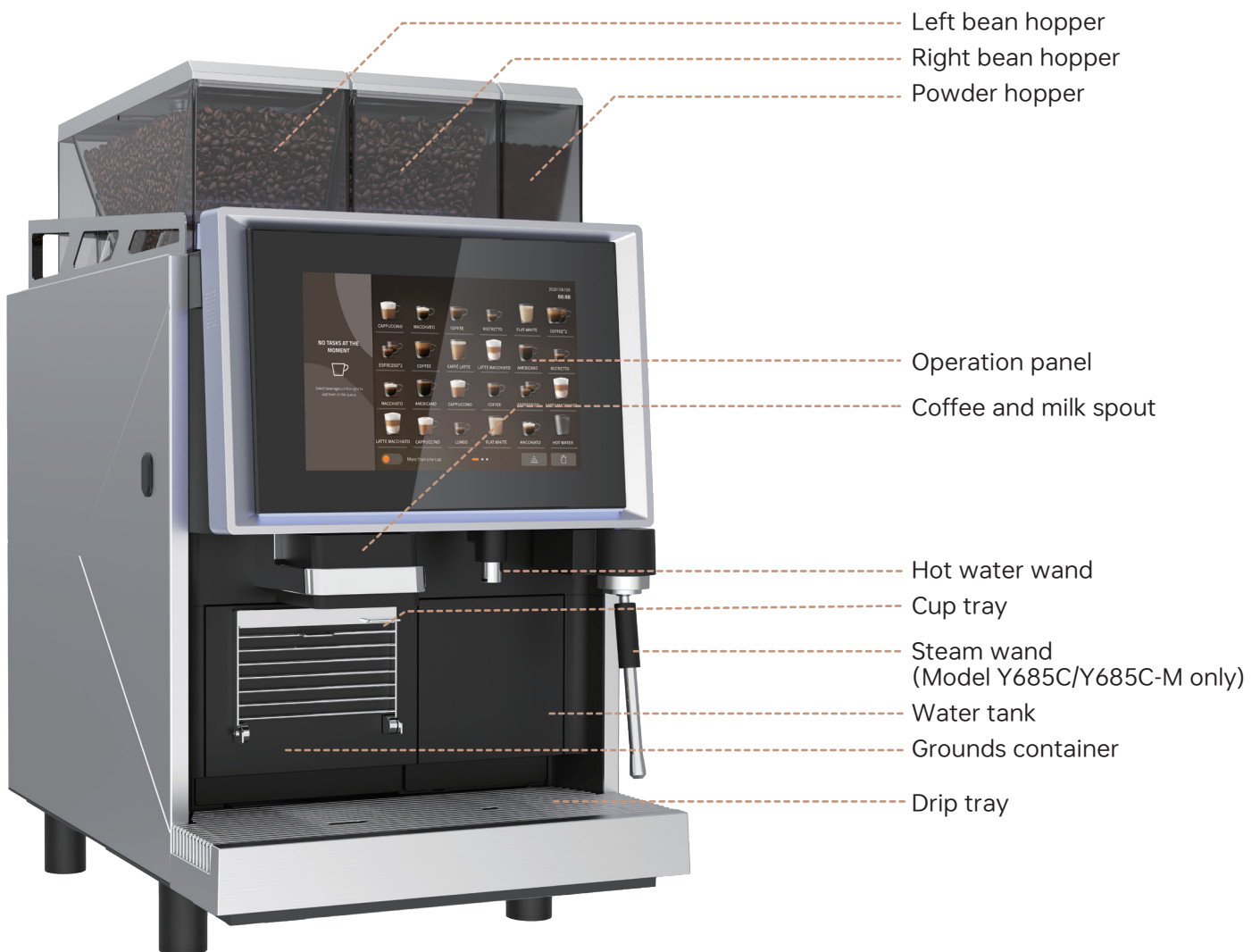

Open the operation panel



Rear of machine

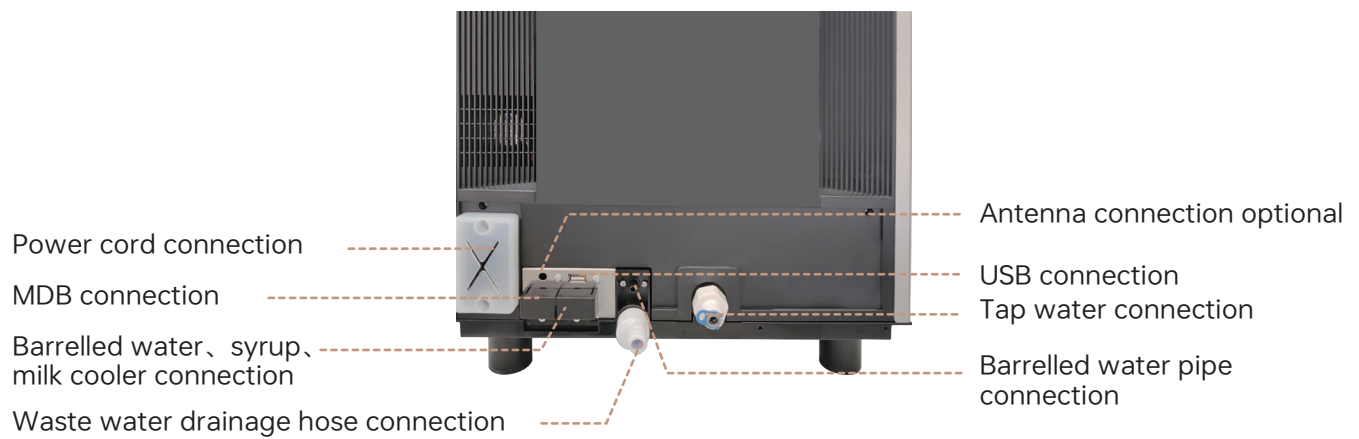

2.2 Screen interface

Y6 series are available with three different kinds of user interfaces-standard, self-service and professional to satisfy the needs of different scenarios. See **page 41** for specific way of interface switchover.

2.2.1 Standard interface

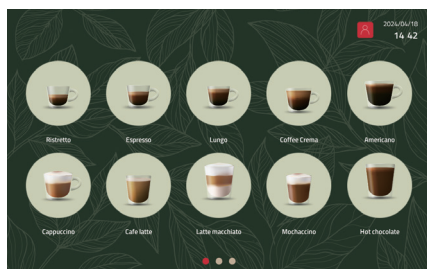

Touching 'Member' icon can set personal coffee recipe

Standard interface is designed to use for non-professional operator or professional personnel. Member function can be performed on the upper right of screen.

2.2.2 Self-service interface



Select language quickly here (four different languages are available)

Specially designed to use in self-service scenarios, such as breakfast store and hotel. User can select language from upper-right corner of screen quickly without access to the menu.













2.2.3 Professional interface







Generally used in commercial scenarios, and the machine needs to assign with professional operating personnel to use.

Continue to order is available in this interface .

2.2.4 Symbols on the screen





Symbol	Name	Description
	Member	Access to membership setting
Logo	Logo	Access to the menu setting
	Scroller	Tips for drinking pages and current page
	Add	Add drinks
	Close	Close current page
	Alert	View the exception message
	Boiler temperature	Display boiler temperature
	Steam boiler temperature	Display steam boiler temperature
	Brew unit position	Display operation status of current brew unit
	Error message	Display error message on the current machine
	Water-flow	Display current water-flow velocity, unit: ml/s
	Inactive	Drink is 'inactive' and cannot be prepared
	Operation steps	Operation steps for current initialization

2.2.5 Symbols in the menu setting

Symbol	Name	Description
	Exit	Return to main page. Need to input PIN code to access to the menu again
	Main page	Return to main page. Do not need to input PIN code to access to the menu again
	Selection	The item is selected or activated
	Edit	Editing this item is permitted

2.3 Scope of delivery

The scope of delivery may vary depending on the device configuration

Part	Picture	Quantity
Tap water connection pipe		1
Tap water connector		2
Waste water drainage hose		1
Thimble		1
Key		1
User manual		1
Filter adaptor		1

2.4 Technical data

Screen dimensions	10.1in
Boiler capacity	0.7L
Steam boiler capacity	0.6L
Water tank capacity	4L
Drip tray capacity	2L
Grounds container capacity	45 Pcs
Coffee spout height	Height 1=100 mm Height 2=160 mm
Permissible water pressure	0.05-0.6MPa
Left bean hopper capacity	1200g
Right bean hopper capacity	1200g
Powder hopper capacity	1200g
Power supply type	220-240V 50/60Hz
Power rating	2500W
Machine dimensions (D*W*H)	560mmx380mmx675mm
Net weight	32kg
Noise value	<70dB(A)



Depending on the model and sales area of the machine, IoT function is optional. Contact customer service for the details

The radio frequencies and parameters used in this equipment are as follows

Radio frequency and parameters	
TD-LTE	■B38; ■B40;
LTE FDD	■B1; ■B3; ■B7; ■B8; ■B20; ■B28
WLAN	■2.4GHz; ■5GHz; ■5.8GHz
Bluetooth	■EDR ■LE
WLAN section details	
Support system	2.4GHz: ■802.11b ■802.11g ■802.11n □802.11ax
	5GHz: ■802.11a ■802.11n ■802.11ac □802.11ax
	5.8GHz: ■802.11a ■802.11n ■802.11ac □802.11ax
Occupied bandwidth	2.4GHz; ■20M ■40M
	5.1GHz; ■20M ■40M ■80M
	5.8GHz; ■20M ■40M ■80M
RFID	Transmitting frequency: 13.56Mhz



The radio technical parameters and frequency range of the machine are only matched with the IoT configuration. Contact customer service for the details

The radio technical parameters and frequency range of this equipment are as follows

Media Types	Commercial fully automatic coffee machine		
Modulation Mode	LTE FDD: QPSK/16QAM TD-LTE : QPSK/16QAM BT: GFSK, $\pi/4$ -DQPSK, 8-DPSK WLAN:CCK DSSS/OFDM/GFSK		
TECHNICAL PARAMETER	Frequency range	Occupied bandwidth	Transmitted power
Targeted value	LTE FDD : Band 1 UL: 1920-1980MHz DL: 2110-2170MHz Band 3: UL: 1710-1785MHz DL: 1805-1880MHz Band 7: UL:2500-2570MHz DL:2620-2690MHz Band 8: UL:880-915MHz DL:925-960MHz Band 20: UL:832-862MHz DL:791-821MHz Band 28: UL:758-803MHz DL:703-748MHz TD-LTE : Band 38: 2570-2620MHz Band 40: 2300-2400MHz BT: 2.400-2.4835GHz WLAN: 2.400-2.4835GHz 5.150-5.350GHz 5.725-5.825GHz RFID: 13.553~13.567MHz	LTE-FDD: $\leq 20/15/10/5/3/1.4$ MHz TD-LTE: $\leq 20/15/10/5$ MHz BT: ≤ 2 MHz WLAN: ≤ 20 MHz ≤ 40 MHz ≤ 80 MHz RFID: 12.543~14.577MHz	LTE FDD: ≤ 25 dBm TD-LTE: ≤ 25 dBm BT: ≤ 11.50 dBm WLAN: 2.4g ≤ 20 dBm 5G ≤ 19 dBm RFID: -32.8 dBuA/m@10m

3. Installation

3.1 Installation tips

1. Only an instructed service-engineer may install the machine.
2. The manufacturer is not liable for injuries caused by an improper mounting of the unit.
3. Installation must use original accessory.
4. Installation personnel will carry out the initial commissioning process for your coffee machine and walk you through the basic functions.



Please contact customer service for further support if you have any questions

3.2 Dimensions

Dimension unit: millimeter

Optional area for connections through counter
breakthrough fresh water, power, waste water hole
Ø60mm

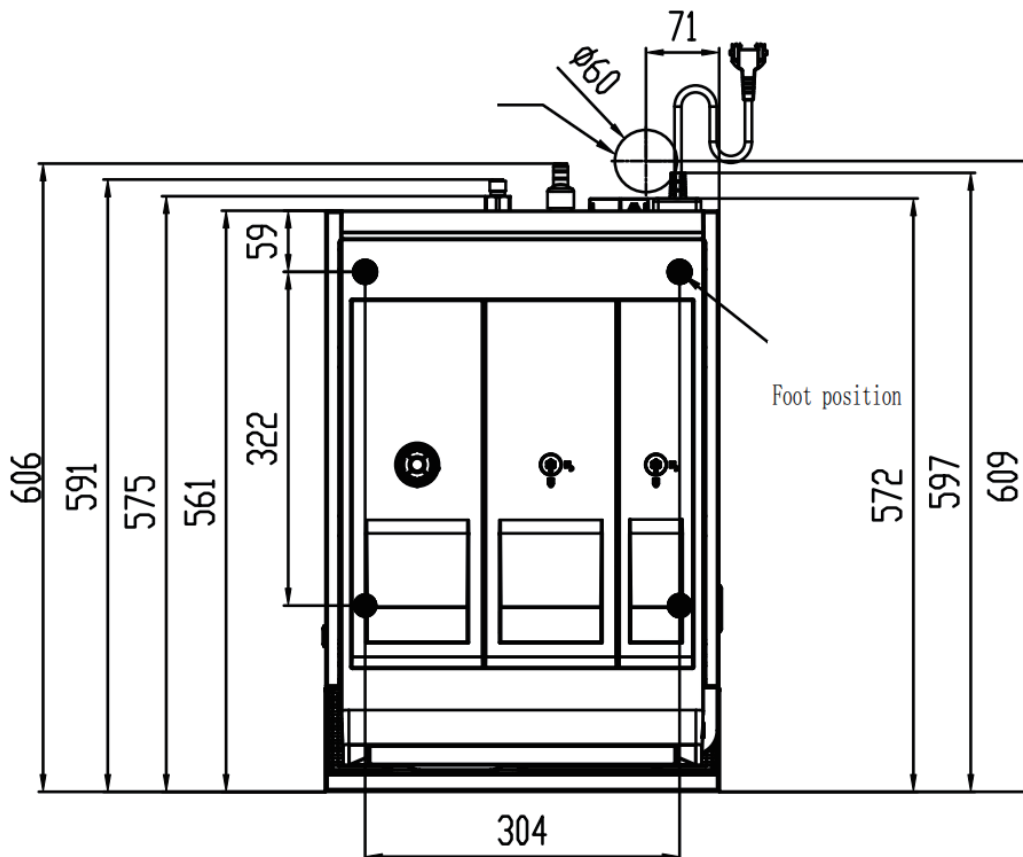

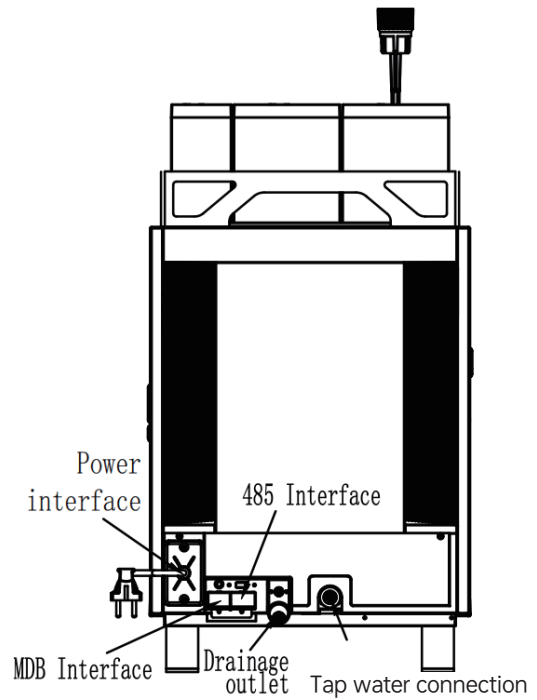
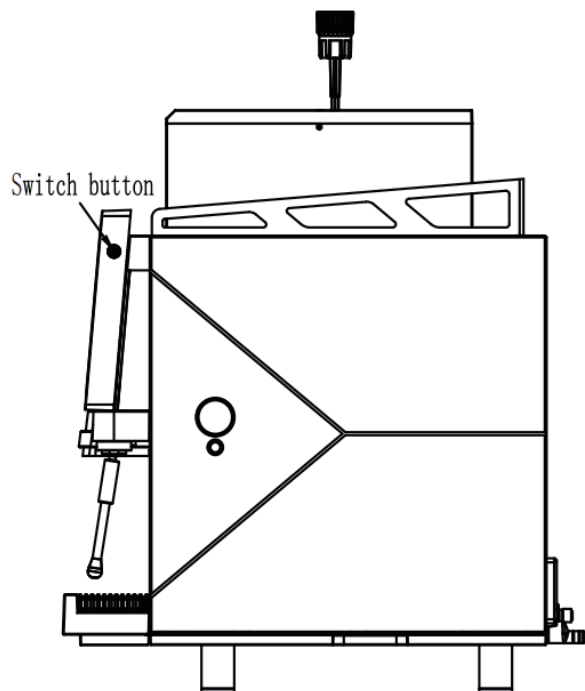
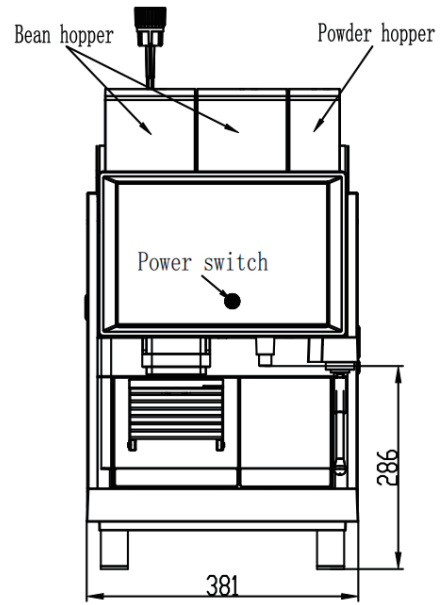
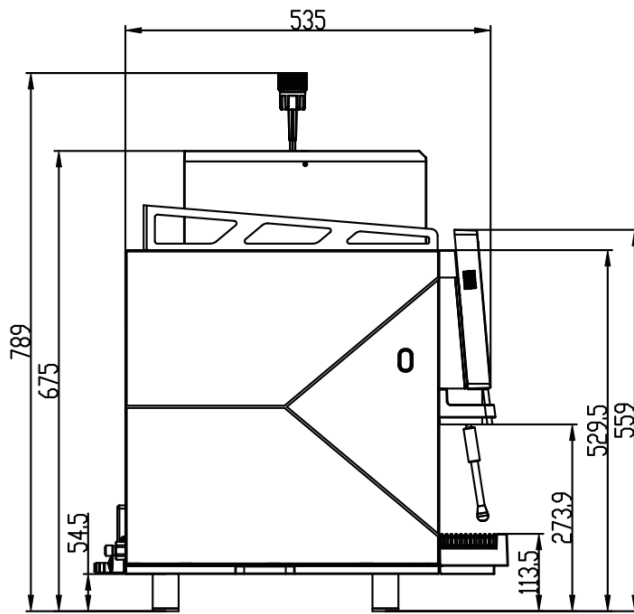

3.3 Installation location

1. The installation location must be dry and protected against water spray.
2. Some condensate, water, or steam can always be discharged from a coffee machine.
3. Do not use the coffee machine outdoors.
4. The machine has to be installed on a solid, level and heat-resistant base.
5. The surrounding temperature must be between 5°C~35°C

3.4 Electrical connection

1. The mains connection must correspond with the voltage, amperage and frequency indicated on the machine label. Installation of wrong or improper electric plugs can cause short circuit, resulting in fire. The plug has to be selected and installed by qualified service personnel only.
2. The Y6 series are electrically safe only when properly earthed as described in the current electrical safety specifications. Check for compliance and, when in doubt, have the wiring thoroughly inspected by skilled personnel.
3. The manufacturer does not take any responsibility for any damage caused by incorrect earthing or improper use of power supply.
4. No action needed from users to shift the product between 50 and 60Hz, product can adapt itself for both 50 and 60 Hz.

3.5 Water supply connection

Tank water supply, tap water supply and barreled water supply are available for the Y6 series. Tank water supply and tap water supply are the standard configurations when the factory setting has been finished. Default water supply is water tank.

3.5.1 Water quality

Total hardness:	4-8dH GH
	70-140 ppm (mg/l)
Carbonate hardness	3-6dH KH/50-105 ppm(mg/l)
Acid content/pH value	6.5-7.5 pH
Chlorine content	<25 mg/l
TDS	30 -150 ppm (mg/l)
Electric conductivity	50-200 S/cm(microsiemens)
Iron content	<0.3 mg/l

To guarantee the required water quality, a water filter system needs to be installed.

3.5.2 Tap water connection

The distance between the machine and the water connection should not be more than 1 meter (to connect the appliance, use the supplied original hose only).

The water pressure must be between 2-6 bar. If the water pressure is more than 6 bar, a pressure reducing valve must be installed.

3.5.3 Barreled water supply connection

Barreled water supply connection needs to use accessories supplied with factory. Please contact customer service for help if you need to use barreled water function.

3.5.4 Automatic waste water drainage connection

The distance between the water drain and the machine should not be more than 1 meter. For proper draining, make sure that the water drain (hose) does not sag.

3.5.5 Water filter installation



1. Choose suitable level from A, B, C according to actual water quality

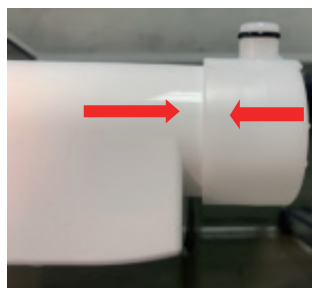

2. Connect water filter to adapter



3. Insert water filter into connector of water tank

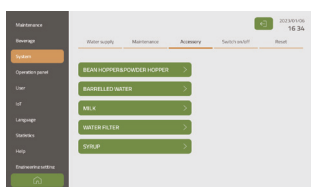

4. Select System Accessory-Water filter

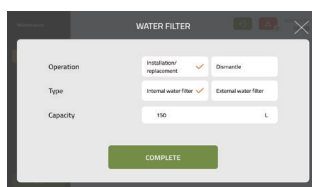

5. Select installation/replacement and internal water filter, input water capacity based on suitable level, then touch 'COMPLETE'

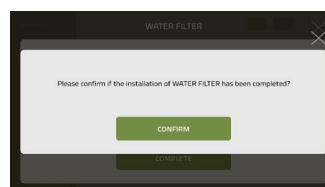

6. Touch 'CONFIRM'



See water filter user manual for capacity of BRITA setting level

4. Start-up for the first time

4.1 Material filling

Adding material into the machine. See **page17** for specific operation.



Please use water tank supply for first time use

4.2 Initially start-up program setting

After switching on the machine initially, access to the setting of start-up program for the first time is available. Specific process as follows:



1. Lift the front operation panel and press the power switch



2. Press the screen power button



3. Screen is on

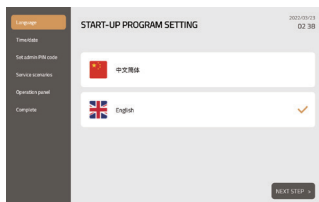

4. Select language

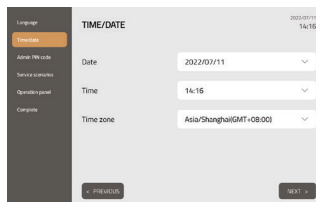

5. Set time and date

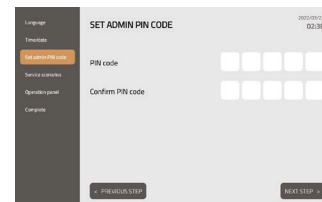

6. Set PIN code

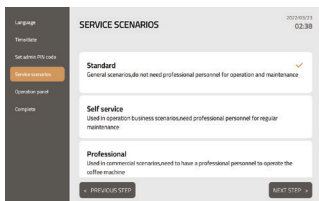

7. Select screen interface

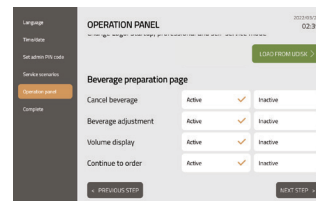

8. Set the panel display

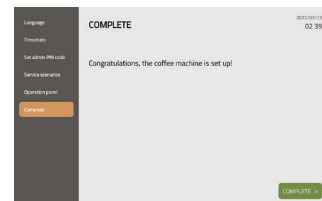

9. Click '**complete**' to finish the setting

5. Operation

5.1 Coffee beans filling



1. Use the key to unlock bean hopper lid (if required)



2. Lift bean hopper lid



3. Add coffee beans

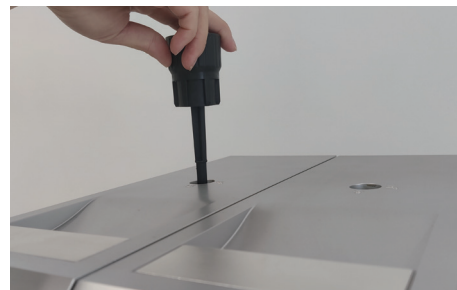

4. Attach lid and lock it (if required)



Never put any objects into the bean hopper or grinder
Otherwise, splinters may be ejected, leading to injury



1. Be careful with filling coffee beans, avoid falling into the gap between bean hoppers
2. Do not pour ground coffee into bean hopper
3. Do not pour any liquids into bean hopper

5.2 Powder filling



1. Use the key to unlock powder hopper lid (if required)



2. Lift powder hopper lid



3. Fill in suitable powder for fully automatic coffee machine

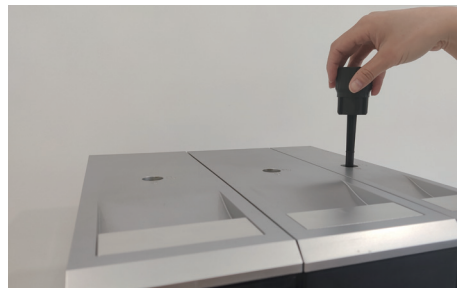

4. Attach lid and lock it (if required)



- 1. Do not pour ground coffee into powder hopper
- 2. Do not pour any liquids into powder hopper

5.3 Water tank filling



1. Pull out the water tank



2. Fill water tank with drinking water



3. Attach water tank (Ensure water tank is installed in position)



- 1. Surface of water can not be over the maximum marking identification of water tank
- 2. Do not fill the water tank with hot water, which may damage machine

5.4 Milk connection



1. Connect milk hose and cleaning hose to milk cooler



2. Insert NTC



3. Connect milk hose (inlet) to metal milk hose



4. Insert NTC and the integrated milk hose into milk container lid



5. Place milk container back



See Milk cooler user manual for specific installation.
Please contact customer service if you have any question.

5.5 Empty bean hopper



1. Use the key to unlock the operation panel (if required)



2. Lift the front operation panel



3. Pull the locking slide towards the front as possible



4. Remove bean hopper upwards



5. Empty and dry the bean hopper



6. Attach the bean hopper



7. Push the locking slide all the way in



Must keep the bean hopper totally dry after cleaning it, then place it back



Pay attention to the position of screen during the operation!
Carelessly touch may lead to the falling of screen and may cause the crush hazard of arm or finger

5.6 Empty powder hopper



1. Use the key to unlock the operation panel (if required)



2. Lift the front operation panel



3. Pull the locking slide towards the forward if possible



4. Remove the powder hopper upwards

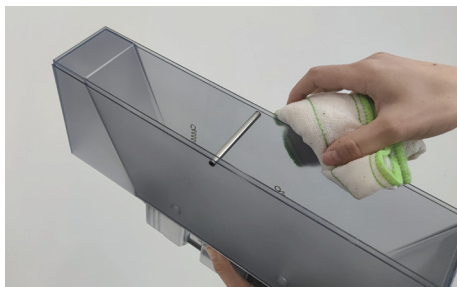

5. Empty and dry the powder hopper



6. Attach the powder hopper



7. Push the locking slide all the way in



Must keep the powder hopper totally dry before placing it back

5.7 Switch on machine

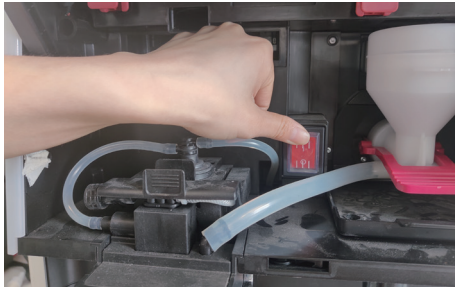

Process of switch on the machine (please see **page 16** start-up for the first time/start-up program.)



Pay attention to the position of screen during the operation!
Carelessly touching may lead to the falling of screen and may cause the crush hazard of arm or finger

5.8 Beverage preparation

5.8.1 Beverage preparation in standard interface



1. Place an appropriate cup under the beverage outlet

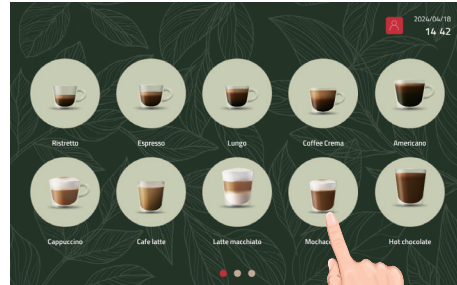

2. Touch beverage icon

3. Beverage in preparation

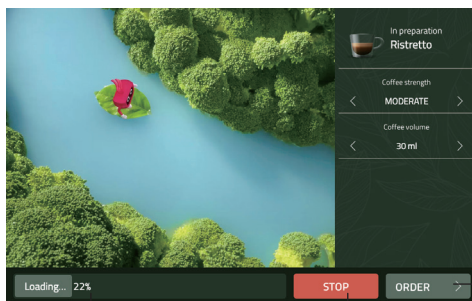

Touch '<'>' can change parameter during the beverage preparation

Touch '**ORDER**' to select another desired beverage

Cancel beverage preparation by touching '**STOP**'

Process bar

5.8.2 Beverage preparation in 'self-service' interface



1. Place an appropriate cup under the beverage outlet



2. Touch beverage icon

3. Beverage in preparation

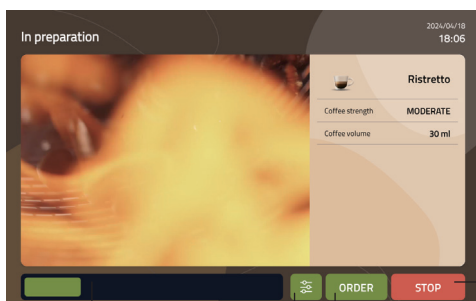

Process bar

Cancel beverage preparation by touching '**STOP**'



Touch '**ORDER**' to select another desired beverage



Change parameter during the beverage preparation

5.8.3 Beverage preparation in 'professional' interface



1. Place an appropriate cup under the beverage outlet



2. Touch beverage icon

3. Beverage in preparation



Process bar

Cancel beverage preparation

4. Queuing function can be used when beverage in preparation. Touch espresso beverage icon when preparing cafe latte, espresso will be displayed in the queuing list as below

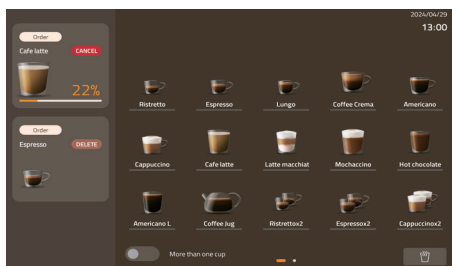

5.9 Steam output (Model Y685C/Y685C-M)

Steam wand is suitable for manually heating and foaming of milk and also applies to heat other drinks



1. Hold a suitable container under the steam spout

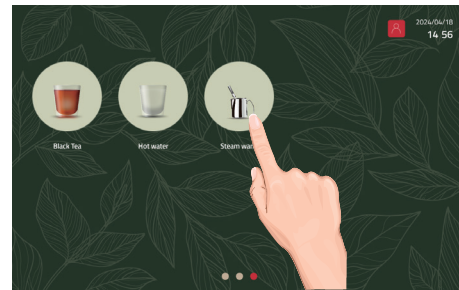

2. Touch steam icon and start dispensing steam



3. Steam is releasing



4. Wipe the steam wand with a damp cloth after using



Touch steam icon, some steam will be released to help for cleaning nozzle and preventing it from clogging

5.10 Grinding coarseness setting

Grinding coarseness could be calibrated by using calibration program. Contact your customer service for the help.

6. Program setting

6.1 Access to the menu

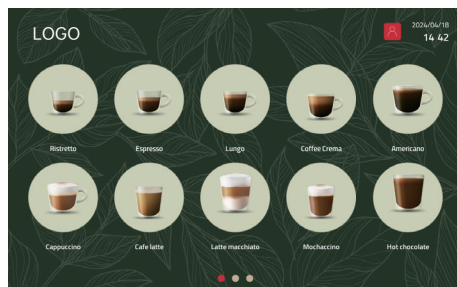

1.Touch logo icon on the upper-left corner

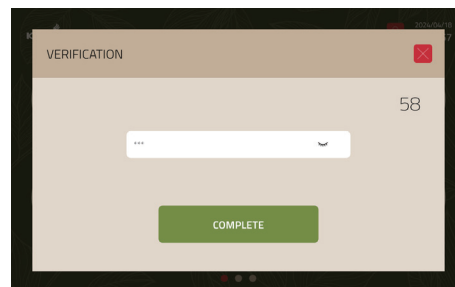

2.Input PIN code and touch ' COMPLETE '

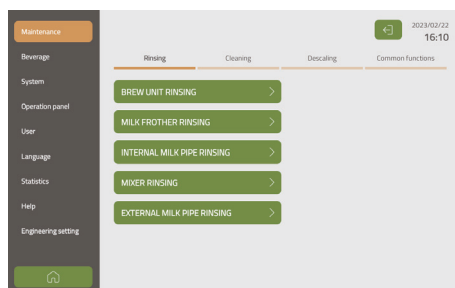

3. Select the target menu



1.PIN codes can be set in the start-up program for the first time. If PIN codes are not set, the default codes are empty
 2.Entering different PIN codes can obtain different menu rights. Specific setting of PIN codes' rights assignment can be checked and changed in the menu of System setting/user/maintenance rights

6.2 Program setting menu tree

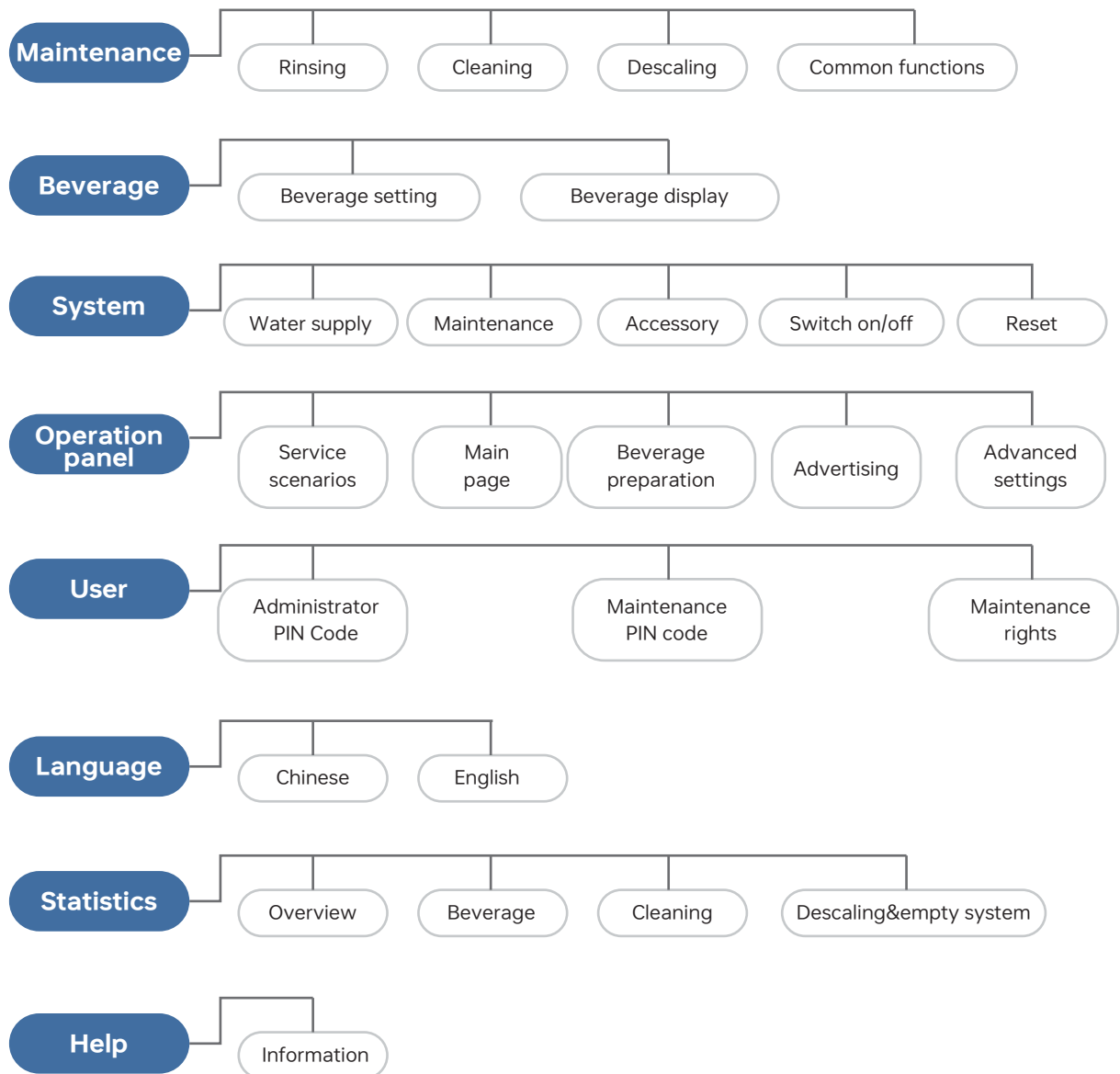

6.3 Maintenance

6.3.1 Overview of cleaning menu

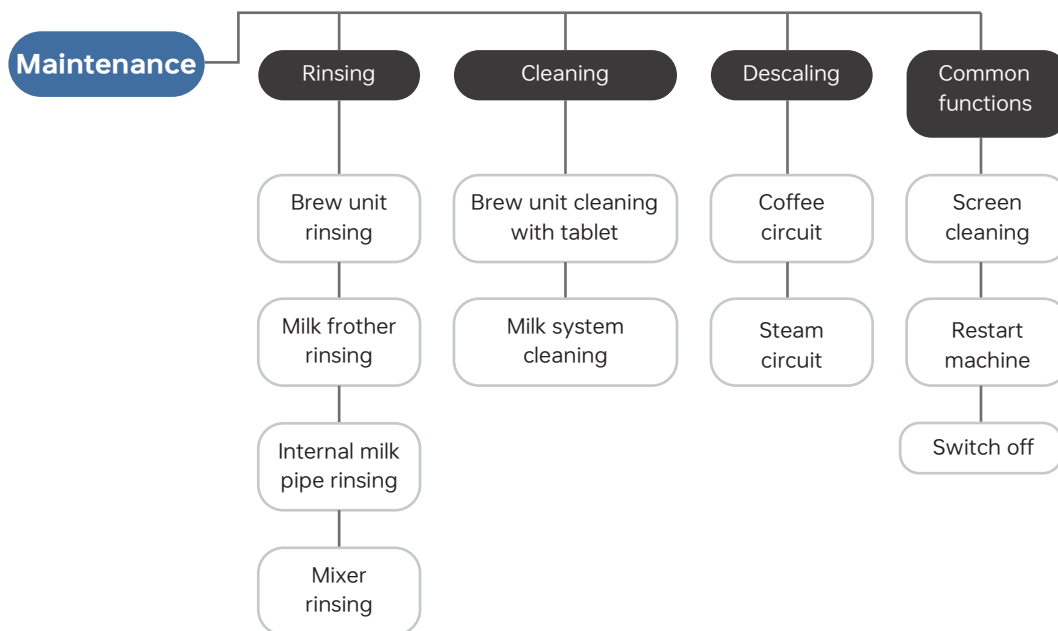

6.3.2 Rinsing

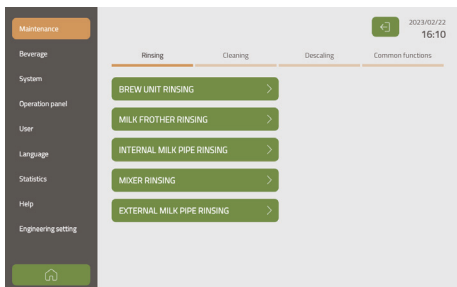

Brew unit rinsing

Immediately carry out hot rinsing of brewing system after tapping it.

Milk frother rinsing

Immediately carry out hot rinsing of milk frother after tapping it.

Internal milk pipe rinsing

Immediately carry out hot rinsing of milk pipe after tapping it.

Mixer rinsing

Immediately carry out hot rinsing of mixer after tapping it.

6.3.3 Cleaning

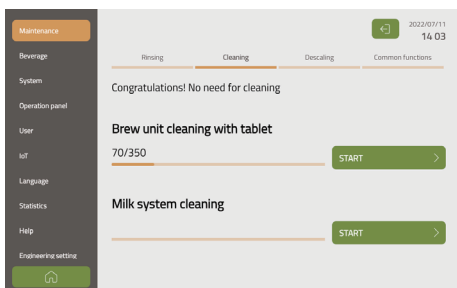

Cleaning brew unit

Immediately carry out tablets cleaning program of brew unit after tapping ' START ', if the message of '**Brew unit cleaning with tablets**' appears on the screen. Cleaning tablets are needed in the process of cleaning. Total duration is approx. 20minutes.

Cleaning milk system

Immediately carry out cleaning process of cleaning milk system after tapping ' START '. Cleaning agents are needed in the process of cleaning. Total duration is approx. 10 minutes.

6.3.4 Descaling



Coffee circuit

Start the program of descaling-coffee circuit after tapping the option, if the message of '**Coffee circuit**' appears on the screen. Descaling powder is used in the process of descaling. Total duration is approx. 40 minutes.



Steam circuit

Start the program of steam circuit descaling after tapping the option, if the message of **'Steam circuit'** appears on the screen. Descaling detergent is used in the process of descaling. Total duration is approx. 40 minutes.

6.3.5 Common function

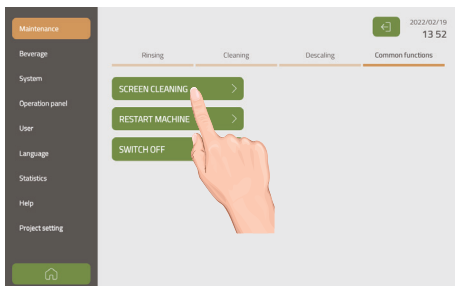

Screen cleaning

Machine will be locked for 15 seconds after tapping **'Screen cleaning'**. Now use a cloth to clean the surface of screen.

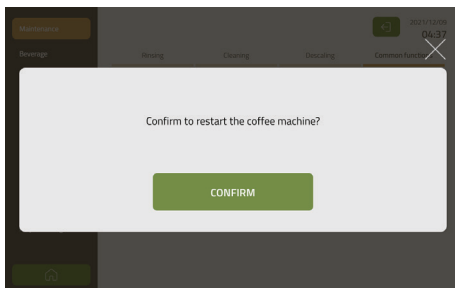

Restart machine

Restart machine system after tapping **'Restart'**.

6.4 Beverage

6.4.1 Beverage setting overview

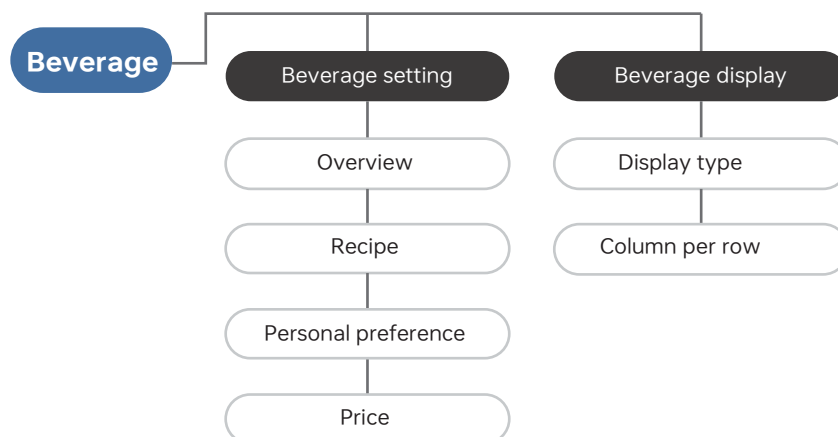

6.4.2 Beverage Settings

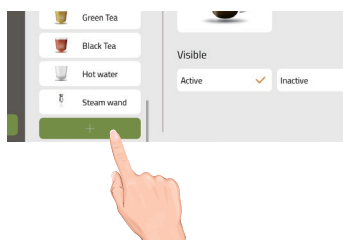
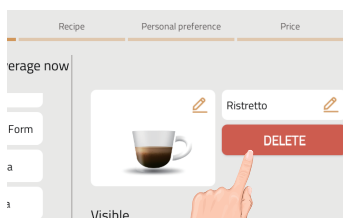
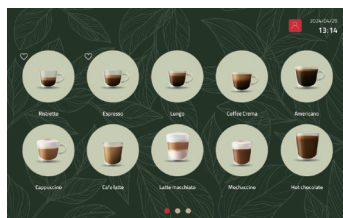
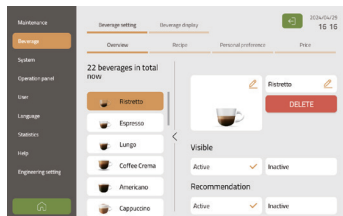
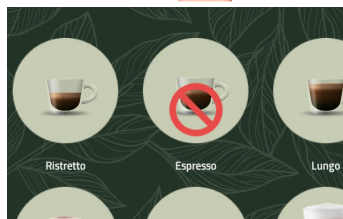
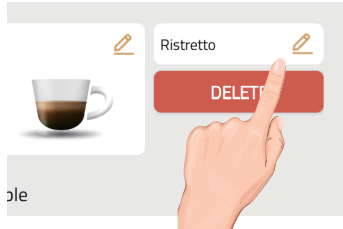
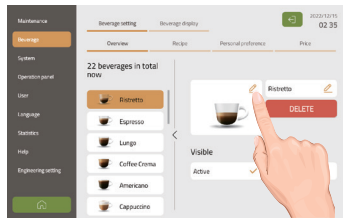

Enter 'Overview' settings

1. Change beverage icon

Change beverage icon after tapping edit icon. Image uploaded from USB stick can be used as beverage icon.

2. Change beverage name

Change beverage name after tapping edit icon. Beverage name can be customized by users using input method.

3. Beverage status

Selecting 'Active' can prepare this beverage. Select 'Inactive', the beverage will be locked and cannot be prepared.

4. Recommendation function

Select 'Active', tiny hearts will be displayed on the upper left of the beverages as shown in the left image.

5. Delete the beverage

Tapping 'Delete' key beneath beverage will delete the beverage from beverage list.

6. Add new beverage

Tap 'Add' that you can select new drink that you want to add from popup list. Change and define name and icon of new beverage after adding new drink into menu list.

Recipe setting

Take Latte for example, after touching latte beverage symbol, you will be able to access to recipe page, beverage parameter setting modification is permitted.

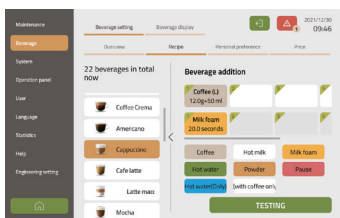

Check current recipe

A total of 5 groups beverage additions can be prepared simultaneously in order. One beverage addition also can be prepared in order

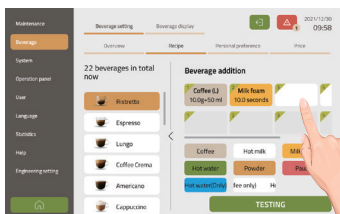

Change recipe order

Press recipe icon (e.g.Coffee) and drag it to change its position in order

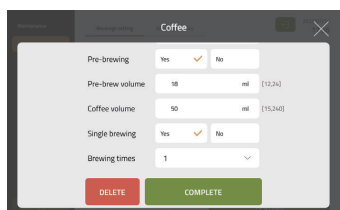

Change recipe parameters

Tap recipe, and changing recipe parameter is permitted. Specific settable value range needs to comply with limited condition of software.

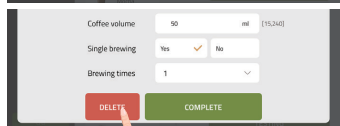

Delete recipe

Access to recipe page and tap 'Delete' button



Add recipe

1. Display beverage recipe composition after tapping recipe.
2. A total of 10 beverage additions can be added.
3. Specific settable value range needs to comply with the limited conditions of software.
4. Every settable recipe parameter as shown in the left image



Add cold milk

For Model Y650C-M&Y680C-M&Y685C-M only

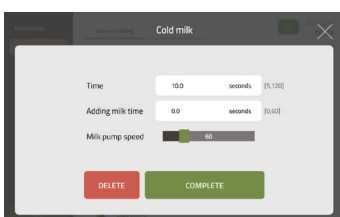

Parameter settings about cold milk as shown in the left image (Model Y650C-M&Y680C-M&Y685C-M only)

Addable recipe parameter

Coffee

Parameter	Value range	Remarks
Bean hopper	Left or right	Default: left
Powder weight	9-22g	Default:10g
Pre-brew volume	0~35ml	Default:0ml
Coffee volume	15~240ml	Default:50ml
Single brewing	yes or no	Default: yes
Brewing times	1~4 times	Default:1

Hot milk

Parameter	Value range	Remarks
Milk temperature	Standard 60-70°C Low 40-50°C	Default: Standard 60-70°C
Time	5~120 seconds	Default: 10 seconds

Milk foam

Parameter	Value range	Remarks
Time	5~120 seconds	Default: 10 seconds

Hot water

Parameter	Value range	Remarks
Water volume	25~450ml	Default: 150ml
Water temperature	Normal	Default: High

Powder

Parameter	Value range	Remarks
Powder weight	0-25g	Default: 20g
Water temperature	High, Medium, Normal	Default: High
Water volume	50~450ml	Default: 100ml

Hot water wand

Parameter	Value range	Remarks
Water volume	25~450ml	Default: 100ml
Water temperature	High, Medium, Low,Cold	Default: High

Steam wand

Parameter	Value range	Remarks
Time	5~120 seconds	Default: 10 seconds

Pause

Parameter	Value range	Remarks
Time	1~20 seconds	Default: 5 seconds

Test

Tap 'Test' to prepare the drink using the modified recipe after recipe setting is completed, and test if the drink can satisfy the expectation.

Personal preference

Option: Active Inactive

Default: Inactive

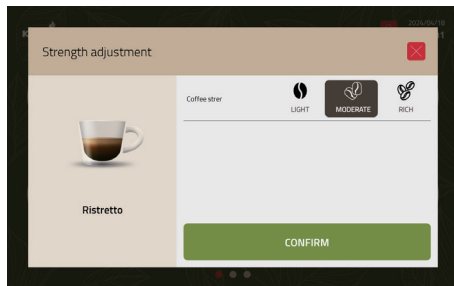

Strength adjustment function in standard mode is available after the personal preference is activated. The left interface pops up after touching the beverage icon.

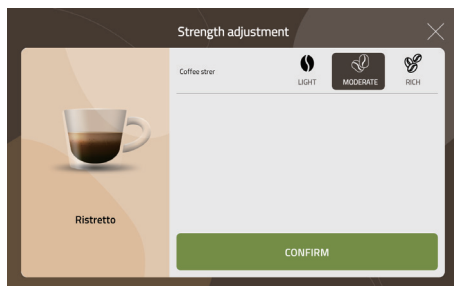

Strength adjustment function in self-service mode is available after the personal preference is activated. The left interface pops up after touching the beverage icon.

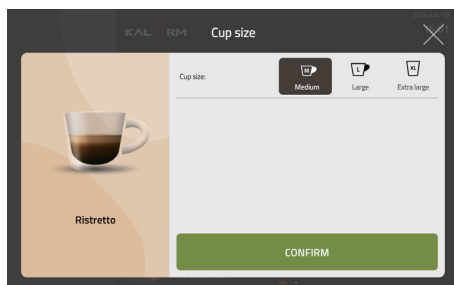

Cup size adjustment function in professional mode is available after the personal preference is activated. The left interface pops up after touching the beverage icon.

6.4.3 Beverage Display

Two modes of beverage display are available: grid layout and menu cards.

Grid layout

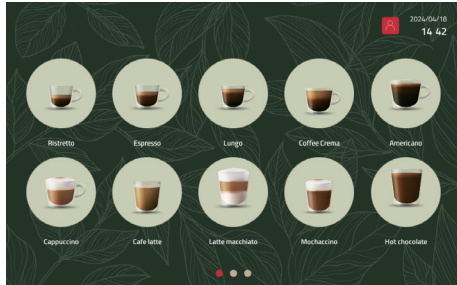

Menu cards



Grid layout

Grid layout parameter setting as follows:

Standard & Self-service interface

Parameter	Value range	Remarks
Column per	4x1,5x1,6x1,4x2,5x2,6x2,4x3,5x3,6x3	Default:5x2

Professional interface

Parameter	Value range	Remarks
Column per	5x1,5x2,5x3,5x4,6x1,6x2,6x3,6x4	Default:5x3

Menu cards

Beverages in the beverage list can be sorted into different menu cards.

Menu cards numbers: 2-7.

1.Touch the cover image of the menu card to replace it with a new one.

New cover image can be selected from photo gallery and also can be loaded from USB stick;

2.Touching '**update the cover name**' can modify the cover name;

3.Touch second level, beverages in the beverage list can be selected and added into menu cards;

6.5 System

6.5.1 Overview of system menu

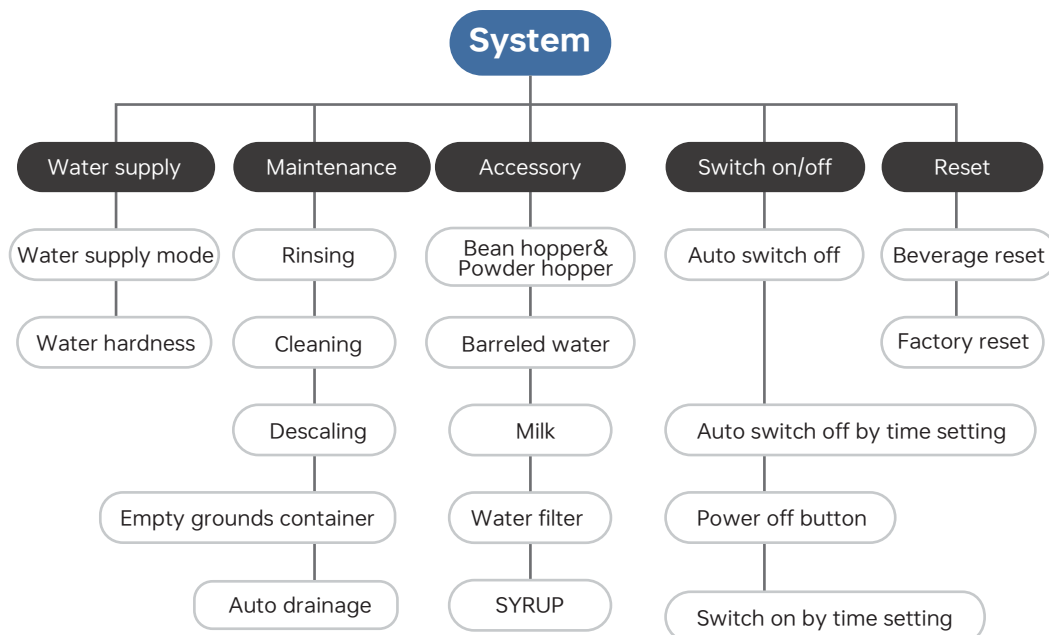

6.5.2 Water supply

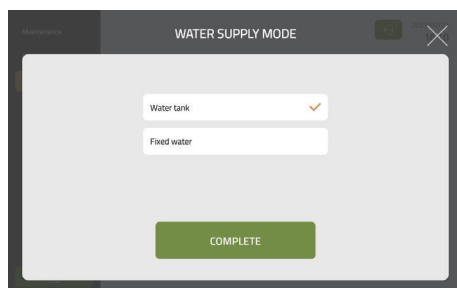

Water supply mode

Water tank supply and fixed water supply are available. Select corresponding water supply mode. Default setting is water tank supply.

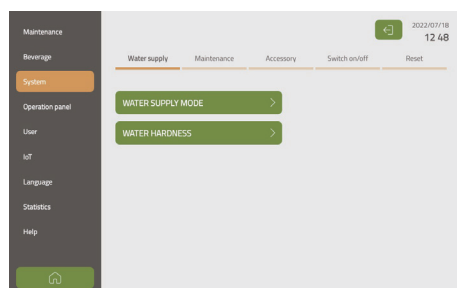

Water hardness

Setting water hardness value for the machine here. Default setting: 5 dh.

6.5.3 Maintenance parameter setting

Rinsing

Rinsing parameter setting as below:

Parameter	Value range	Remarks
Warm-up rinsing	30 minutes 1~4 hours	Default: 30 minutes
Brew unit auto rinsing	Off / 5-20 minutes	Default: Off
Milk frother auto rinsing	Off / 5-20 minutes	Default: 30 minutes
Mixer auto rinsing	Off / 5-20 minutes	Default: Off

Cleaning

Parameter setting of brewing unit cleaning with tablets as below:

Parameter	Set range	Remarks
Brew unit cleaning interval	≥ 0 cup	Default: 350 cups
Compulsory brew unit cleaning interval	≥ 0 cup	Default: 450 cups

Descaling

Water hardness, water flow and water filter installation or not, which determine the liter and time remaining before descaling. Parameter setting of descaling as below:

Parameter	Set range	Remarks
Coffee circuit descaling warning	≥ 0 liter	Default: 2500 liters
Coffee circuit forced descaling	≥ 0 liter	Default: 3600 liters
Steam circuit descaling warning	≥ 0 seconds	Default: 15725 seconds
Steam circuit forced descaling	≥ 0 seconds	Default: 18880 seconds

Empty grounds container

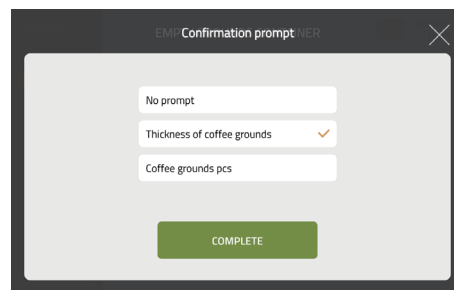
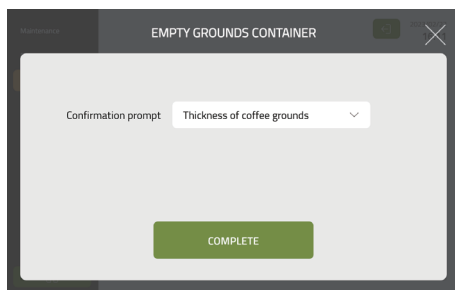

1. Select ' **No prompt** ', ' **Empty grounds container** ' will not be displayed on the screen.
2. Select ' **Thickness of coffee grounds** ', ' **Empty grounds container** ' will be displayed when brew unit running steps reach to 1706.
3. Select ' **Coffee grounds pcs** ', ' **Empty grounds container** ' will be displayed when the coffee grounds pcs reach to 25. (default value), with a set range of 20-40.

6.5.4 Accessories

Bean hopper&Powder hopper

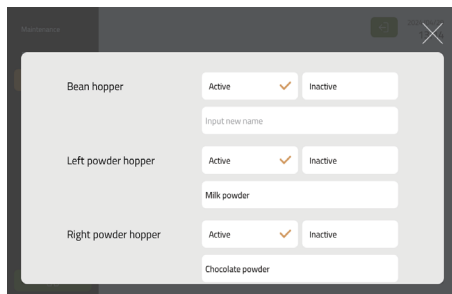

Select '**Active**' here, then tap '**Complete**' if you need to use bean hopper or powder hopper.

Barreled water

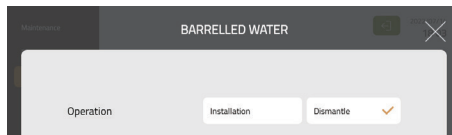

1. Select '**Dismantle**' if barreller water isn't connected to the machine;
2. Select '**Installation**' here, then tap '**complete**' if you need to use barreller water, and machine will be restarted to complete settings.
3. Default setting: '**Dismantle**'.

Milk cooler



1. Select '**INSTALL MILK COOLER**' if using milk cooler, just follow the instructions on the display.

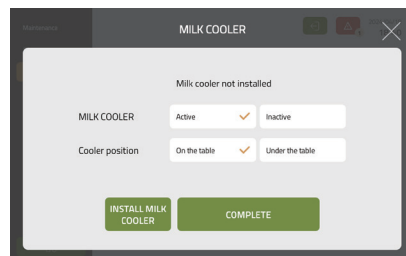

1. Select the cooler position before installing it, just follow the instructions on the display. (Model Y650C-M&Y680C-M&Y685C-M only)



See milk cooler user manual for specific installation. Please contact customer service if you have any question

Water filter

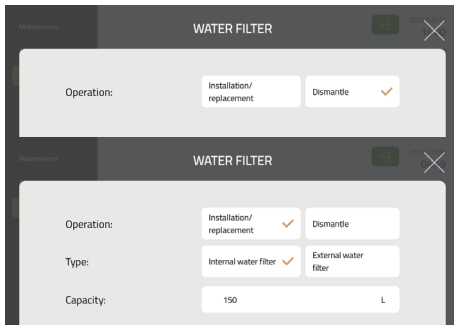

1. Select '**Dismantle**' if not installing the water filter;
2. Select '**Installation/replacement**' here if installing or replacing filter cartridge. Need to select the type of filter cartridge and input capacity here.
3. Default setting: '**Dismantle**'.

Syrup

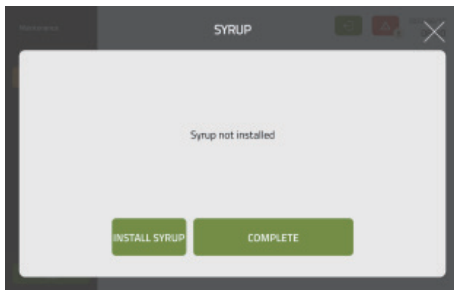

1. Select '**INSTALL SYRUP**' if using syrup. Just follow the instructions on the display.



See syrup user manual for specific installation. Please contact customer service if you have any question

6.5.5 Switch off

Auto switch off countdown

Set the auto switch off countdown here, like auto switch off the machine in 8 hours

Parameter	Set range	Remarks
Auto switch off countdown	1~24 hours / Never switch off	Default: 4 hours

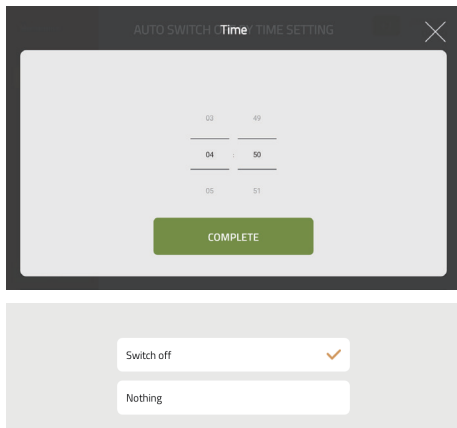

Auto switch off by time setting

Set the time of auto switch off here, like 9:15 am.

Switch off button

1. Select '**Switch off**', press power button for 3 seconds to turn off the screen.
2. Select '**Nothing**', the function of screen power switch is disabled.



Screen power switch

6.5.6 Reset

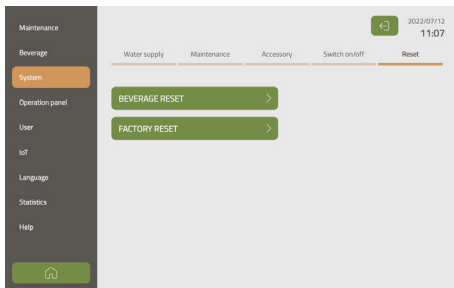

Beverage reset

Restore all relative parameters of beverage to factory default settings.

Factory reset

Restore all parameters of machine to factory default settings

6.6 Operation panel

6.6.1 Service scenarios

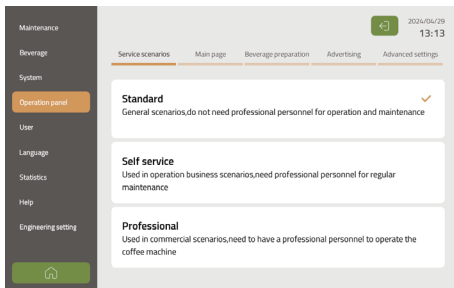

Select interface mode displayed on the screen. Specific introduction of each interface mode displayed on the screen see **page 7**.

6.6.2 Main page

Membership function (Under Standard mode only)

Option: Active Inactive

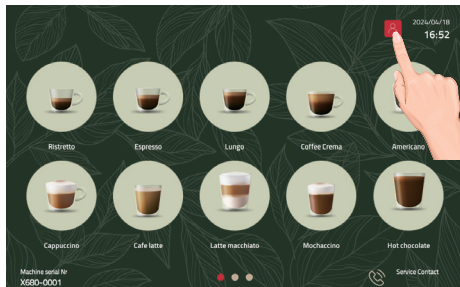

1. Select '**Active**', tap membership key in the upper-right corner of screen, then create member and favorite drinks list.
2. Select '**Inactive**', membership key is not displayed.

Serial number

Option: Active Inactive



1. Select '**Active**', machine serial number is displayed in the lower left corner of screen.
2. Select '**Inactive**', machine serial number is not displayed.

Service call

Option: Active Inactive



1. Select '**Active**', service call is displayed in the lower right corner of screen.
2. Select '**Inactive**', service call will not be displayed.

LOGO Change

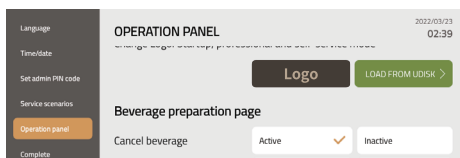

Touch edit key to change logo displayed on the screen. Load new Logo image from USB stick.



Backgrounds of LOGO image used in start-up page, professional mode and self-service mode must be black

Error message (Under Self service mode only)

Option: Error Warning

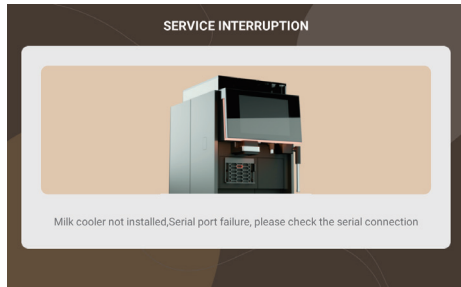

1. If ' **Error** ' mode is selected, machine will be locked by related alarm and Service interruption page will pop out



2. if ' **Warning** ' mode is select, alarm will be hided under triangle alarm symbol at upper right conner

Language setting (Under Self service mode only)

#1 #2

Sub language setting



Different language options can be set and displayed at upper right conner on home page, and dual language can be active or inactive.

Shortcut funtion (Under Professional mode only)

Shortcut #1 Shortcut #2

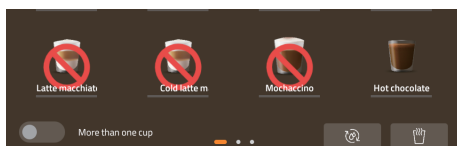

Different shortcut function can be selected and displayed at lower right conner on home page. Related function will be activated by clicking the symble.

6.6.3 Beverage Preparation

Cancel beverage

Option: Active Inactive

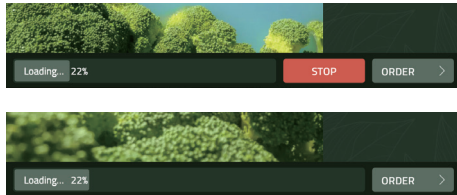

- 1.If selecting '**Active**', drink preparation can be canceled by touching '**stop**'
- 2.Select '**Inactive**', '**stop**' will not be displayed.

Recipe adjustment

Option: Active Inactive

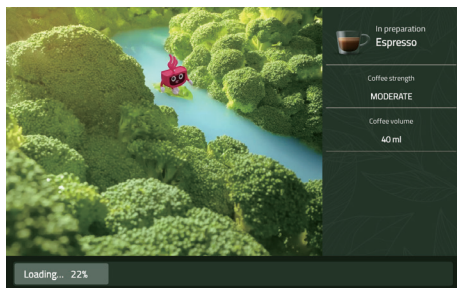

- 1.Select '**Active**', drink recipes could be adjusted by touching left and right key when the beverage is in production.
- 2.Select '**Inactive**', drink recipes could not be adjusted when the beverage is in production.

Volume display

Option: Active Inactive

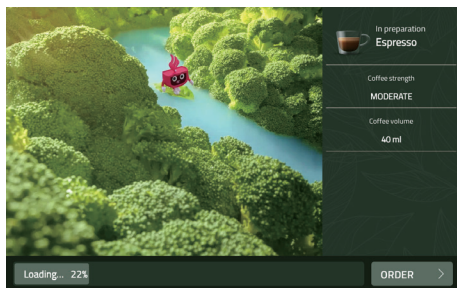

- 1.Select '**Active**', drink recipes will be displayed when the beverage is in production.
- 2.Select '**Inactive**', drink recipes will not be displayed when the beverage is in production.

Continue to order

Option: Active Inactive

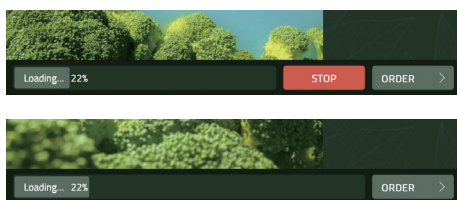

- 1.Select '**Active**', touch '**ORDER**' to select next drink.
- 2.Select '**Inactive**', '**ORDER**' will not be displayed

Cup confirmation

Option: Active Inactive

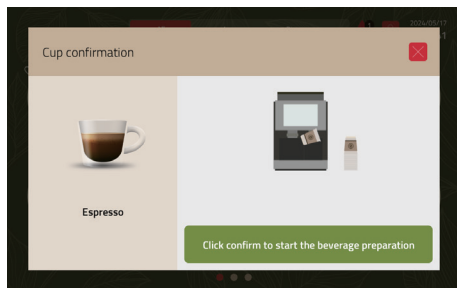

1. Select '**Active**', cup confirmation page will be displayed before making beverage.
2. Select '**Inactive**', cup confirmation page will not display.

Ingredient choice

Option: Active Inactive



1. If select '**Active**', heart-shape symble will appear next to the drinks icon
2. Select Inactive '**Inactive**', it will not be showed up.

6.6.4 Advertising

AD - Standby

Set advertisement videos when the machine is standby. Advertising resources could be loaded from USB stick.

Parameter	Set range	Remarks
Waiting time	0~100seconds	Default: 60 seconds
Volume	0~100%	Default: 20%
Cycle type	Infinite loop ; Exit automatically after playing	Default: Exit automatically after playing
Single image Play time	0~100 seconds	Default: 10 seconds



Advertising setting is available here, videos and images used can be loaded from USB stick

AD - Welcome

Set advertisement videos when the machine is started.

Parameter	Set range	Remarks
Volume	0~100%	Default: 20%
Single image play time	0~100 seconds	Default: 5 seconds



Video requirements: MP4 format, proportion 16:9, recommended resolution ratio 1280x800, Video bitrate less than 3000kbps and 100M, image format: PNG, JPG, JPEG, recommended resolution ratio 1280x800

AD - Beverage in preparation

Set advertisement videos when the beverage is in preparation.

Parameter	Set range	Remarks
Volume	0~100%	Default: 30%
Single image play time	0~100 seconds	Default: 5 seconds



Video requirements: MP4 format, proportion 4:3, recommended resolution ratio: 890x700, Video bitrate less than 3000kbps and 100M, image format: PNG, JPG, JPEG, recommended resolution ratio: 890x700

6.6.5 Advanced settings

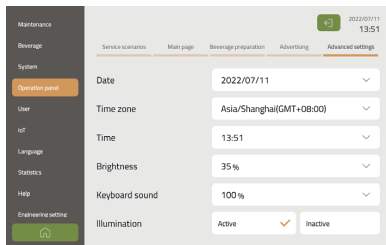

Date

Set local date

Time zone

Set local time zone

Time

Set local time

Brightness

Set brightness. Default: 60%

Keyboard sound

Set keyboard sound volume.
Default: 100%

Illumination

Option: Active Inactive

Illumination

Active, Inactive

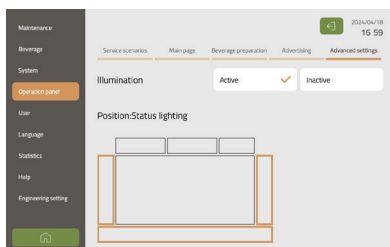

1. Select '**Active**', screen, bean hoppers and powder hoppers are illuminated.

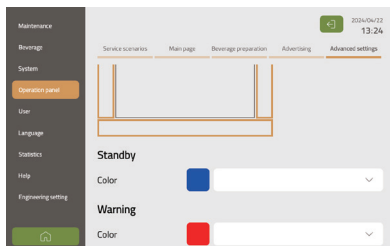

2. Touch desired position for illumination setting, for example, touch the '**Left bean hopper**'.

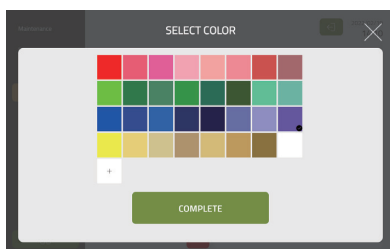

3. Enter the color menu to set the color for standby and alarm illumination. Select target color from preset various colors, shown as left image

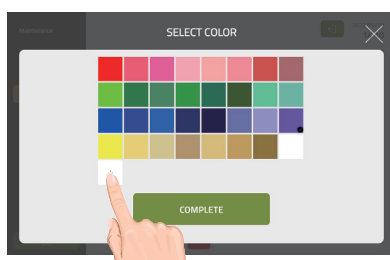

In addition, customization color can be set. Access to customization interface by touching '+'

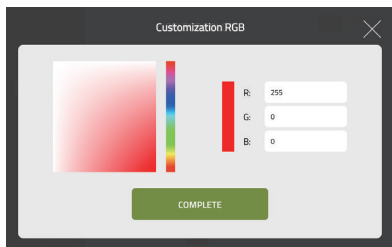

6.7 User

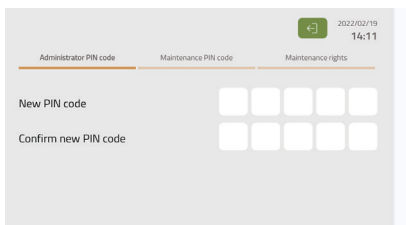

Different user rights can be assigned with corresponding PIN code.

6.7.1 Administrator PIN Code

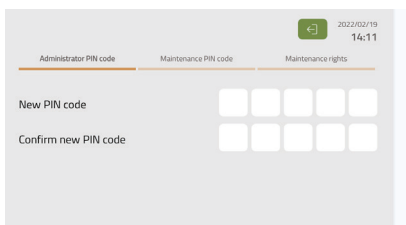

Set admin PIN code, which is formed from 5 digits. Inputting correct pin code can view all rights of menu.

6.7.2 Maintenance PIN code

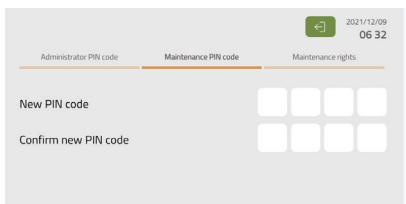

Set maintenance PIN code here, which is formed from 4 digits. Inputting correct pin code can view assigned maintenance rights.

6.7.3 Maintenance rights

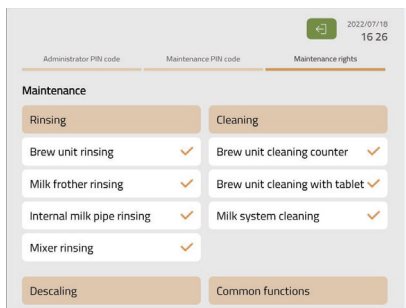

Set specific rights for maintenance PIN code here.

6.8 Language

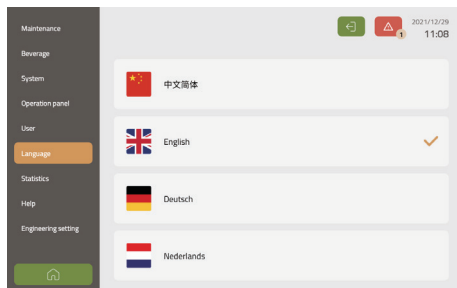

Display available languages here.
Select language.
Default language setting is English.

6.9 Statistics

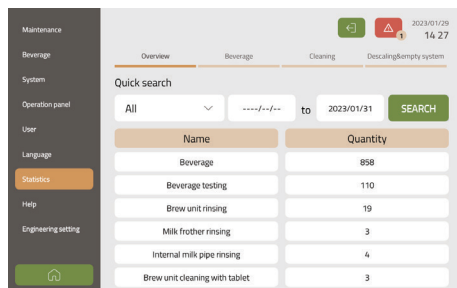

View the history records of various beverage preparation data, total drink qty, care and maintenance here.

6.9.1 Beverage

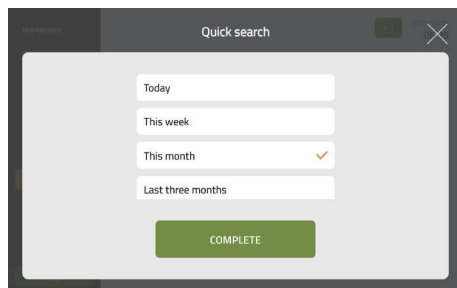

Quick search

Data can be viewed by 1 week, 1 month, 3 months, current date, half year, one year.

Viewing the data of certain time can be customized. The data could be presented in two ways: tables and graphs.

6.9.2 Cleaning

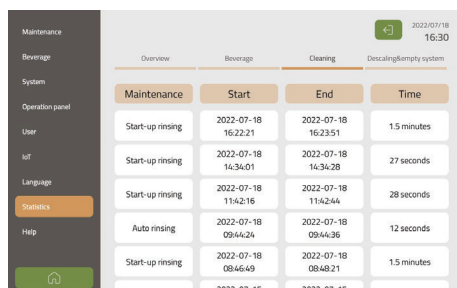

Specific time records of various cleaning items can be viewed here, including the start time, ending time and duration time of cleaning items.

6.9.3 Descaling/empty system

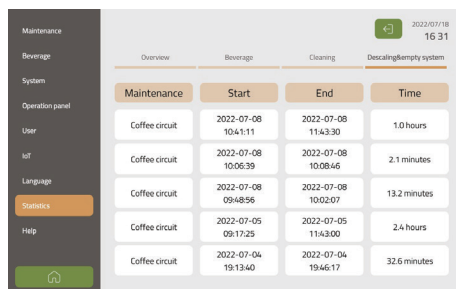

Maintenance	Start	End	Time
Coffee circuit	2022-07-08 10:41:11	2022-07-08 11:43:30	1.0 hours
Coffee circuit	2022-07-08 10:06:39	2022-07-08 10:08:46	2.1 minutes
Coffee circuit	2022-07-08 09:48:56	2022-07-08 10:02:07	13.2 minutes
Coffee circuit	2022-07-05 09:17:25	2022-07-05 11:43:00	2.4 hours
Coffee circuit	2022-07-04 19:13:40	2022-07-04 19:46:17	32.6 minutes

History records of descaling and emptying water system can be viewed here.

6.10 Help

View Machine Information

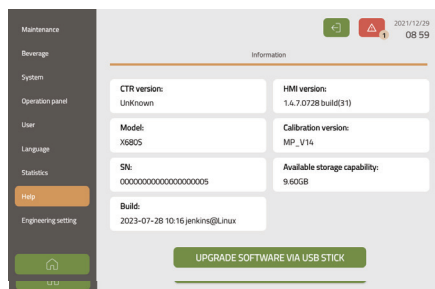

Information	
CTR version: Unknown	HMI version: 1.4.7.0728 build(31)
Model: X6805	Calibration version: MP_V14
S/N: 00000000000000000000000000000000	Available storage capability: 9.65GB
Build: 2023-07-28 10:16 jenkins@Linux	

Information regarding this machine could be viewed here including:

- CTR version (PCB software)
- HMI version (Screen software)
- Android system version
- Calibration file version
- Serial number of machine
- Available storage space of screen
- Model of the machine

Upgrade software via USB stick

Program of machine can be upgraded by USB stick



Software program upgrade needs to be instructed by professional technician, contact customer service personnel for help

6.11 IOT function

IOT function is optional because of the model and sales area, contact customer service for the details if you have any questions.

7. Cleaning and maintenance

The perfect coffee experience depends on a perfectly cleaned coffee machine. Clean your coffee machine at least once a day and more frequently if necessary. Clean the machine immediately if you find that it is dirty or clogged.

7.1 Cleaning intervals overview

Cleaning intervals	Operation	Type
Daily (or needed)	Brew unit rinsing	Automatic or manual
	Milk frother rinsing	Automatic or manual
	Mixer rinsing	Automatic or manual
	Empty drip tray	Manual
	Empty grounds container	Manual
	Clean the screen	Manual
	Clean steam wand	Manual
	Clean milk frother	Manual
Weekly	Clean the brew unit	Manual
	Clean the bean hopper	Manual
	Clean the powder hopper	Manual
	Clean the mixer	Manual
	Clean the water tank	Manual
	Clean the milk frother	With cleaning agents
If presents	Brew unit cleaning	When the screen shows a message
	Descaling	When the screen shows a message
	Filter change	When the screen shows a message

7.2 Parts preparation

Parts	Usage
Cleaning tablet	Brew unit cleaning with tablet
Tablet key	Add brew unit cleaning tablet
Milk system cleaning agents	Milk system cleaning
Descaling powder	Descaling
Key	Open the front panel, bean hopper and powder hopper
Milk hose brush	Clean milk hose manually
Damp cloth	Clean the hoppers, screen, machine surface, steam wand

7.3 Daily cleaning

7.3.1 Brew unit rinsing/ Milk frother rinsing/ Mixer rinsing

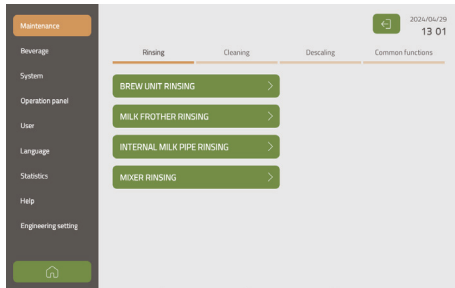

1. Every automatic rinsing intervals could be set in Menu / Maintenance setting, then rinsing will be processed automatically after reaching the setting condition.



2. Rinse immediately by manual selection. Enter '**Maintenance/Rinsing**' menu, and touching each rinsing option can rinse at once.



Hot water will be dispensed from coffee spout during rinsing be careful to avoid scalding

7.3.2 Empty grounds container

Empty grounds container (at least once per day)



1. Remove grounds container



2. Pour out the coffee grounds



3. Clean it thoroughly with fresh water



4. Dry and place the grounds container back

7.3.3 Empty drip tray

The drip tray is below the coffee grounds container. Clean the drip tray as needed (at least once per day)



1. Remove the drip tray



2. Pour out waste water



3. Clean it thoroughly with fresh water



4. Dry and place the drip tray back



Must clean the two metal plates in front of the drip tray and keep them dry, otherwise, **'Empty drip tray'** will be misreported

7.3.4 Clean the screen

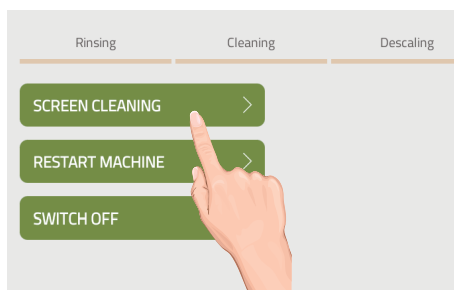

Enter **'Maintenance/common functions'**. Select **'SCREEN CLEANING'** to start a 15- second countdown. Now screen can be wiped by a dry cloth.

7.3.5 Clean the steam wand (Y685C/Y685C-M)



Use a damp cloth to wipe steam wand after each use



Touch **'steam'** to release some steam, which is helpful for cleaning nozzle

7.4 Weekly cleaning

7.4.1 Cleaning milk frother manually

1. Switch off the machine and open the operation panel.



2. Press the buckle and pull up the nozzle of milk frother.

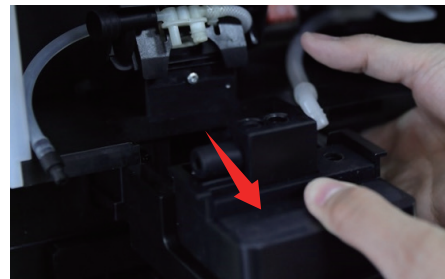
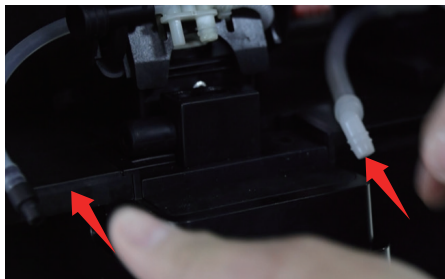

3. Disconnect the pipe connection



4. Pull out milk frother forward



5. Dismantle milk frother

6. Clean milk frother with fresh water and place it back



Specific process of cleaning milk frother manually can be viewed from ['Help/video/cleaning milk frother manually'](#)

7.4.2 Cleaning brew unit manually



1. Switch off the coffee machine and disconnect mains plug firstly



2. Remove grounds container and drip tray. Now brew unit is fully accessible



3. With one hand reaching into the chute under the brew unit and push the locking up and release it



4. Slowly guide the brew unit all the way down, tilt and pull forward. Remove the brew unit and hold it firmly



5. Clean the brew unit under running water



6. Dry the brew unit with a cloth. Allow to dry completely before reinstalling in the coffee machine

7.4.3 Clean the bean hopper



Bean hoppers can be cleaned when needed or at regular intervals (recommendation: weekly).

1. Switch off coffee machine firstly and disconnect mains plug.
2. Remove the bean hopper lid;
3. Open the display panel by using the key and lift the panel up;
4. Pull the lock plate in the bean hopper to release the hopper;
5. Remove the bean hopper, empty it out, and clean it with a damp cloth.
6. Dry the bean hopper completely and place it back and lock it.
7. Lock the screen and place it back.



Specific assemble and disassemble process of bean hopper can see **page 19 ' Empty bean hopper '**

7.4.4 Clean the powder hopper

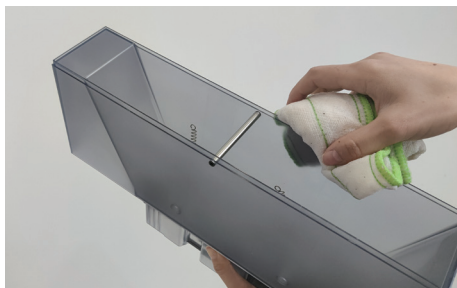

1. Switch off coffee machine firstly and disconnect mains plug.
2. Open display panel by using the key and lift the panel up;
3. Pull the lock plate in the powder hopper to release the hopper.
4. Remove the powder hopper, empty it out, and clean it with a damp cloth.
5. Dry the powder hopper completely and place it back and lock it.
6. Lock the screen and place it back.



Specific assemble and disassemble process of bean hopper can see **page 21 ' Empty bean hopper '**

7.4.5 Clean the mixer

1. Switch off the coffee machine firstly and disconnect mains plug



2. Open the display panel by using the key and lift the panel up



3. Release the lock plate in the mixer to release the mixer

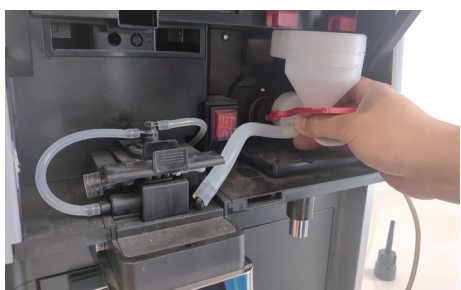

4. Pull the mixer bowl forward by the handle



5. Pull off the mixer hose running from the mixer bowl to the spout and remove it



6. Clean it with a damp cloth

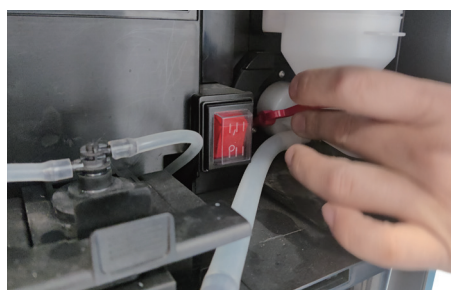

7. Dry the mixer completely and install it back and lock it

8. Lock the screen and place it back



Cleaning will be more frequently according to the consumption of powder

7.5 Brew unit cleaning if presents

A message **'Brew unit cleaning with tablet'** will appear on the screen when the coffee system needs to be cleaned with a tablet. Total duration is approx. 10 minutes

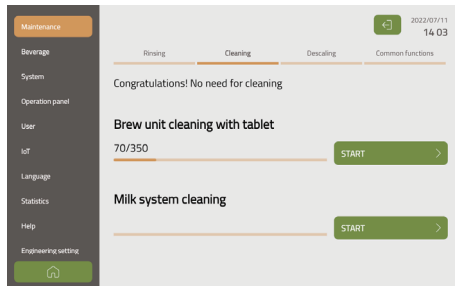

1. Access to **'Maintenance/cleaning'** menu

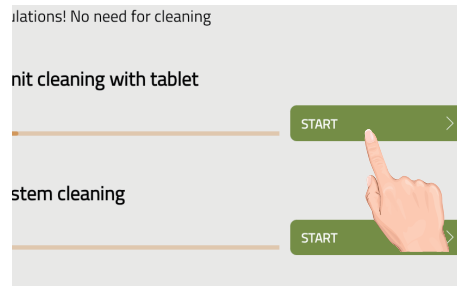

2. Touch **'START'** button



3. Touch **'CONFIRM'** to start the cleaning

4. Perform every step according to the message displayed on the screen



If brew unit cleaning with tablets is not performed in time, the screen will be locked after reaching the preset compulsory cleaning intervals, and the machine cannot be used until cleaning process has been completed

7.6 Milk system cleaning if presents

A message **'Milk system cleaning'** will appear on the screen when the milk system needs to be cleaned with cleaning liquid. Total duration is approx. 10 minutes

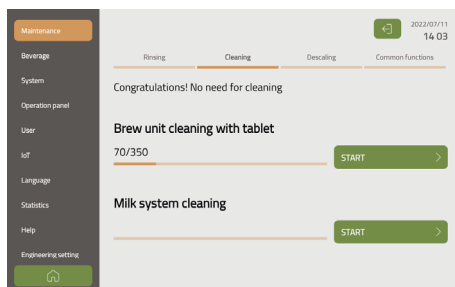

1. Access to **'Maintenance/cleaning'** menu

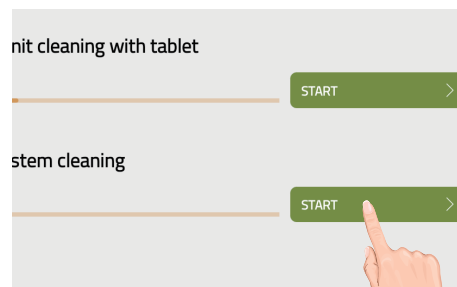

2. Touch **'START'** button



3. Touch '**CONFIRM**' to start the cleaning
4. Perform every step according to the message displayed on the screen



During cleaning, hot cleaning solution will flow out of the spout. So never reach under the spouts while cleaning

7.7 Descaling if presents

The water hardness, water flow, and whether a water filter is used determine the schedule for descaling. Descaling time is calculated by the Y6 series and displayed.

7.7.1 Coffee circuit descaling



If descaling is not be carried out in time, the screen of machine will be locked after reaching the preset compulsory descaling, and the machine cannot be used until descaling process has been completed

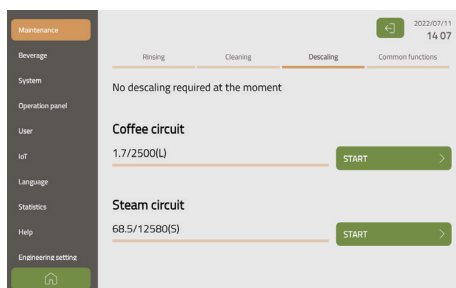

1. Access to '**Maintenance/cleaning**' menu

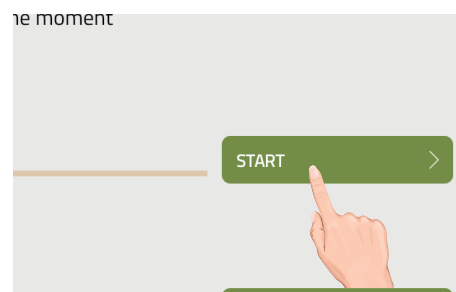

2. Touch '**START**' button



3. Touch '**confirm**' to start the descaling
4. Perform every step according to the message displayed on the screen



During cleaning and descaling, hot cleaning solution or descaling solution flows out of the spout. So never reach under the spouts while descaling

7.7.2 Steam circuit (steam system) descaling



A message '**Steam circuit descaling**' will appear on the screen when the steam system needs to be descaled with descaling powder. Steps of starting-up steam circuit are similar with steps of descaling coffee circuit. Please operate strictly according to messages displayed on the screen.

8. Messages and explanation

8.1 Operational messages



When an error occurs, the machine will display an error message, which indicated by a red triangle in the upper- right corner of operator panel. Tap this symbol to obtain more information.

Information	Possible solutions
Place water tank	Check whether the water tank is installed correctly or place it back
Place screen back	Place screen back
Place drip tray	Place drip tray back
Place grounds container	Place grounds container back
Place left bean hopper	Place left bean hopper back
Place right bean hopper	Place right bean hopper back

Information	Possible solutions
Low water level of water tank	Fill water tank with fresh water
Empty drip tray	Pour out the water in the drip tray, if drip tray has been emptied but message is still remaining, clean and dry the two metal water level sensors in front of the drip tray
Fill left bean hopper	Fill left bean hopper with coffee beans
Fill right bean hopper	Fill right bean hopper with coffee beans
Fill powder hopper	Fill powder hopper with powder
Use lower temperature milk	Milk temperature lower than 30°C
Please install brew unit	Place brew unit back

8.2 Error message

The error message will appear automatically when the entire system is affected by an error. Restart the machine if serious problems appear.

1. Switch off the machine by main switch when restarting the machine
2. Please contact service technician if the machine cannot be started or if you are unable to fix error

Error code	Error description	Possible solutions
E1	Main PCB error	1.Try to restart the machine 2.If error message is still remaining after restarting, please switch off the machine and contact customer service.
E2	Boiler temperature too high	
E3	Steam boiler temperature too high	
E4	Boiler temperature too low	
E5	Steam boiler temperature too low	
E6	Boiler heating too fast	
E7	Steam boiler heating too fast	

Error code	Error description	Possible solutions
E8	Boiler heating too slow	1.Try to restart the machine 2.If error message is still remaining after restarting , please switch off the machine and contact customer service
E9	Steam boiler heating too low	
E10	Boiler heating error	
E11	Steam boiler heating error	
E12	Water tank detected error	
E13	Water mixing valve error	
E400	Coffee circuit error	
E401	Steam circuit error	
E402	Brew unit error	

Error code	Error description	Possible solutions
E403	Coffee multi-way valve error	1.Try to restart the machine 2.If error message is still remaining after restarting , please switch off the machine and contact customer service
E404	Steam multi-way valve error	
E405	Mixer error	
E406	Left powder motor error	
E90	Steam boiler level sensor error	

9. Decommissioning

9.1 Preparing for decommissioning

1. Clean the machine by using all cleaning and rinsing function.
2. Cleaning after emptying bean hopper and powder hopper.
3. Clean beverage spout and milk pipe manually.
4. Clean brew unit manually.
5. Clean mixer manually.
6. Clean drip tray and grounds container etc.

9.2 Short-term decommissioning (within one month)

1. Empty coffee circuit (Have your coffee machine drained by your service technician).
2. Disconnect the machine from the power supply.
3. Shut off the water supply.
4. Switch off the add-on units and disconnect them from the power supply.

9.3 Long-term decommissioning (over one month)

Some components may no longer function as they should if they have been stored or unused for long periods

Coffee machine must be maintained, installed, and cleaned before preparing any drinks.

1. Have your coffee machine drained by your service technician.
2. Remedial maintenance may be required when commissioning the machine again if it has been stored in excess of 6 months. Please contact service personnel for support.

10. Transport and storage

10.1 Transport

Protect the machine from mechanical damage and adverse environmental condition during transport and storage.

1. Protect the machine from falling or tipping over.
2. Restore external packaging of machine well to use in transportation.
3. In order to avoid the damage to machine, water in the coffee machine must be emptied before transportation.
4. After the completion of emptying water circuit, dry the machine, inside and out.



Empty water circuit must be performed by professional technician, please contact service personnel for support.



If the program of emptying water circuit is performed, coffee system needs to re-perform the program that has been carried out in the first time use when using the machine again.

10.2 Storage

Storage conditions must be fulfilled:

1. Permissible temperatures: -10 to +50°C.
2. If the machine has not been drained and emptied completely, it must not be stored at sub-zero temperatures.
3. Set the machine up in a standing position.
4. Machine system emptied.
5. Machine and accessories packaged, preferably in their original packaging.

10.3 Recommissioning after prolonged periods of storage or non-use

Coffee machine may no longer function if they have been stored or unused for periods in excess of 6 months. Contact your service team for information regarding restoring and recommissioning your machine.

11. Disposal

When disposal of coffee machine, some internal spare parts are still worth using again, pay attention to deal with old parts in an environmentally neutral way.

1. Beans, powder and coffee grounds can be composted.
2. Observe the information on the label when disposing of any unused cleaning agent.
3. Dispose of the fluids from the cleaning container or the drip tray in the wastewater system.



Dispose of electronic parts separately



Dispose of plastic parts in accordance with their marking

